

# RHINO MOTION CONTROLS

RMCS-225X

High-Torque Encoder DC Servo Motor and Driver

Digital Step/Direction input interface (Max. 15Vdc and 7A)



## Installation Manual and Datasheet

<http://www.rhinomc.com>

<http://www.rhinomotioncontrols.com>

Page 1

**High-Torque Encoder DC Servo Motor and Driver [RMCS-225X]**

# RHINO MOTION CONTROLS

RMCS-225X

High-Torque Encoder DC Servo Motor and Driver

Digital Step/Direction input interface (Max. 15Vdc and 7A)



## Key Features

- Direct replacement for 50W stepper motor and drive
- Zero-Backlash DC Servo Motor Performance with 0.2deg encoder resolution
- 10RPM,60RPM,100RPM,200RPM,300RPM,600RPM,900RPM High-Torque DC Servo Motor
- Metal Gearbox and Gears with 18000RPM base motor
- 0.2deg resolution Quadrature Optical Encoder on output shaft
- High-Current DC Servo motor driver integrated with the motor
- Fixed stepping of 1800 steps per rotation on output shaft
- Industrial Grade Aluminum housing for motor and drive
- Compatible with NEMA 23 mounting setup
- 2.5V, 3.3V and 5V compatible PULSE and DIRECTION inputs with 2-wire opto-isolated interface

## Description

Thank you for purchasing RMCS-225X, High-Torque Encoder DC Servo Motor and Driver. RMCS-225X is Rhino Motion Controls introductory Encoder DC Servo motor control solution designed as a replacement for 50W or less stepper motors and drives.

The RMCS-225X integrates a High-Torque DC motor with 18000RPM base motor and Metal Gearbox and Gears for 10RPM, 60RPM, 100RPM, 200RPM, 300RPM, 600RPM and 900RPM options. It houses a 0.2deg resolution quadrature optical encoder on its output shaft that allows for superior position and speed control with zero back-lash. The position of the DC servo motor is controlled by a STEP/PULSE and DIRECTION digital interface similar to stepper motors.

The PULSE/STEP, DIRECTION inputs are optically isolated. Both inputs work with 2.5V, 3.3V or 5V logic drive signals. The input drive current is 5mA at 2.5V so almost all logic family (74LS, 74HC, etc.) can be used to drive these inputs. Each input provides individual anode and cathode connections to the opto-isolator allowing for multiple input drive interfaces.

## Technical Specifications

Specification	Min	Max	Units	Comments
Supply Voltage	11	15	Volts DC	Between V+ and GND
Supply Current	0.5	7	Amps	No-load to stalled condition
PUL and DIR Voltage	2.5	7	Volts DC	Between + and – input pins
Ambient Temp.	0	70	Celsius	
Humidity	0	95%		Non condensing
Step Frequency	—	100	kHz	
Direction Setup time	500	—	ns	Steps is clocked on positive edge
PUL and DIR Voltage	2.5	7	Volts DC	Between + and – input pins

<http://www.rhinomc.com>

<http://www.rhinomotioncontrols.com>

Page 2

**High-Torque Encoder DC Servo Motor and Driver [RMCS-225X]**

# RHINO MOTION CONTROLS

RMCS-225X

High-Torque Encoder DC Servo Motor and Driver

Digital Step/Direction input interface (Max. 15Vdc and 7A)



## Mechanical Specifications

Specification	Details
Dimensions (L * W * H)	120mm * 60mm * 60mm
Weight	350gms

## Encoder Specifications

Specification	Details
Counts per Rotation	1800 counts
Degrees per count on output shaft	0.2deg per count

## Caution

- Read this document carefully before installing and using this product
- Inputs voltage to the drive must not exceed the maximum of 15VDC or it may damage the drive
- Reversing polarity power supplied to the drive will damage the drive or power supply
- Excess humidity or condensation on the drive may damage the drive
- Voltage in excess of 7V on the input terminals may damage the speed controller
- Reverse voltage in excess of 7V between the input terminals may damage the controller
- Keep the motor and drive in a ventilated or cool temp.
- Make sure the supply is well regulated and there is minimal voltage ripple
- Make sure that the digital inputs are wired as per information in this manual
- Reverse polarity on the digital inputs of PULSE/DIR can damage the drive

## Power and Input Terminal Assignments

Terminal No.	Terminal Name	Wire Color	Description
Terminal 1	GND	BLACK	Ground should be connected to negative of supply of battery
Terminal 2	DIR-	BROWN	Direction -Ve signal connected to anode of opto-isolator
Terminal 3	DIR+	RED	Direction +Ve signal connected to cathode of opto-isolator
Terminal 4	PUL-	ORANGE	Step/Pulse -Ve signal connected to anode of opto-isolator
Terminal 5	PUL+	YELLOW	Step/Pulse +Ve signal connected to cathode of opto-isolator
Terminal 6	V+	GREEN	V+ should be connected to positive of supply or battery

## Shaft Locked or High Load Error State

If for some reason the DC motors output shaft is not able to rotate and achieve the position commanded the drive might go into an error state to protect the motor and drive from over-heating and damage. The power to the drive must be reset to enable the drive to function normally again.

<http://www.rhinomc.com>

<http://www.rhinomotioncontrols.com>

Page 3

**High-Torque Encoder DC Servo Motor and Driver [RMCS-225X]**

## Control Signal Connection NPN pull-down

In this connection technique all the signal +ve inputs are connected to a common high voltage VCC. The opto-isolators LED is turned-on by a pull-down on the -ve terminals by an NPN-transistor output

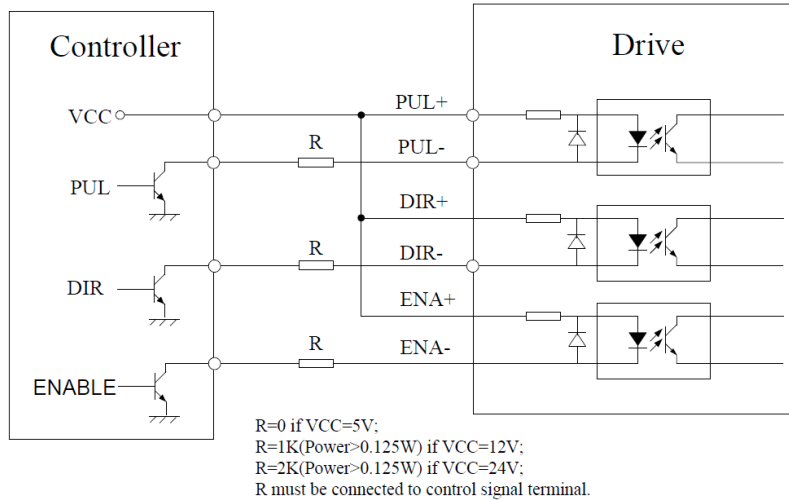

## Control Signal Connection PNP pull-up

In this connection technique all the signal -ve inputs are connected to a common low voltage GND. The opto-isolators LED is turned-on by a pull-up on the +ve terminals by an PNP-transistor output

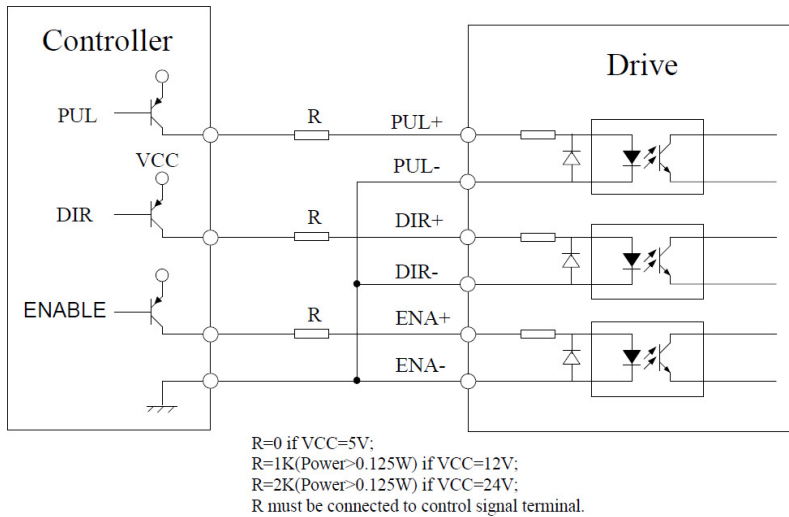

# RHINO MOTION CONTROLS

RMCS-225X

High-Torque Encoder DC Servo Motor and Driver

Digital Step/Direction input interface (Max. 15Vdc and 7A)



## Control Signal Connection Differential

In this connection technique each input is differential controlled and no necessity for a common voltage

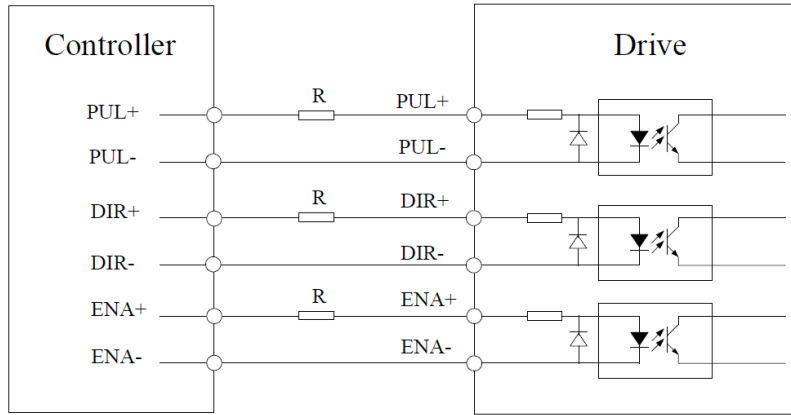

R=0 if VCC=5V;  
 R=1K(Power>0.125W) if VCC=12V;  
 R=2K(Power>0.125W) if VCC=24V;  
 R must be connected to control signal terminal.

## Guide to General Problems

Problem Symptom

Possible Reasons and Solutions

Problem Symptom	Possible Reasons and Solutions
Motor is not rotating	<p>Drive is not powered up</p> <p>Correct inputs are not being provided to update the motor speed</p> <p>Drive is in high load or shaft locked error state and needs to be reset</p>
Erratic Motion on Motor or Drive Resets	<p>Power supply voltage not stable or regulated</p> <p>Power supply not able to supply enough current to change the speed or direction</p> <p>Digital input signals are not connected properly or not adequate</p> <p>Digital input signal interference due to power supply or environmental noise</p>
Excessive Motor or Drive Heating	<p>Load on the motor is excessive or irregular</p> <p>Drive is damaged</p> <p>Power supply voltage is too high</p> <p>Not enough cooling or ventilation for motor or drive</p>

## Power Supply Selection

A high-torque DC motor requires high current during startup and during high load or irregular load conditions. The general rule of thumb to make sure your power supply is adequate for a DC motor is to make sure it can supply the maximum current required by the motor during stall condition. For RMCS-225X this is 7 Amperes. This doesn't necessarily have to be its continuous current capability but it should be able to provide a pulse of 7 amperes during startup of the motor. It is also good practice to have sufficient low ESR decoupling capacitors on the output of the supply before you connect it to a DC motor drive. This is to make sure that the motor driver does not reset or suffer from variations in speed due to an insufficient or unregulated supply.

<http://www.rhinomc.com>

<http://www.rhinomotioncontrols.com>

Page 5

# RHINO MOTION CONTROLS

RMCS-225X

High-Torque Encoder DC Servo Motor and Driver  
Digital Step/Direction input interface (Max. 15Vdc and 7A)



## Service and Support

Service and support for this product are available from the Rhino Motion Controls Web site (<http://www.rhinomc.com>) and our customer service email: [info@rhinomc.com](mailto:info@rhinomc.com)

## Six-Month Warranty

Rhino Motion Controls ([rhinomc.com](http://rhinomc.com)) warrants its products against defects in materials and workmanship for a period of 6 months from shipment delivery. During the warranty period, Rhino Motion Controls will either, at its option, repair or replace products which proved to be defective.

## Exclusions

The above warranty does not extend to any product damaged by reasons of improper or inadequate handlings by customer, improper or inadequate customer wirings, unauthorized modification or misuse, or operation beyond the electrical specifications of the product and/or operation beyond environmental specifications for the product.

## Obtaining Warranty Service

To obtain warranty service, please contact our customer service department at [info@rhinomc.com](mailto:info@rhinomc.com) before returning product for service. Please make sure that you have gone through this entire installation manual and datasheet before deciding that your product is liable for replacement or repair under this 6-month warranty. Customer shall prepay shipping charges for products returned to Rhino Motion Controls for warranty service, and Rhino Motion Controls shall pay for return of products to customer.

## Warranty Limitations

Rhino Motion Controls makes no other warranty, either expressed or implied, with respect to the product. Rhino Motion Controls specifically disclaims the implied warranties of merchantability and fitness for a particular purpose. Some jurisdictions do not allow limitations on how long and implied warranty lasts, so the above limitation or exclusion may not apply to you. However, any implied warranty of merchantability or fitness is limited to the 6-month duration of this written warranty.

## Disclaimer

Copyright © Rhino Motion Controls, 2012

Neither the whole nor any part of the information contained in, or the product described in this manual, may be adapted or reproduced in any material or electronic form without the prior written consent of the copyright holder.

This product and its documentation are supplied on an as-is basis and no warranty as to their suitability for any particular purpose is either made or implied.

This document provides preliminary information that may be subject to change without notice.

---

<http://www.rhinomc.com>  
<http://www.rhinomotioncontrols.com>

Page 6

**High-Torque Encoder DC Servo Motor and Driver [RMCS-225X]**