

Model Number
RMCS- 1020

NEMA17 STEPPER MOTOR 7.0 KGCM - PREMIUM QUALITY

Mechanical Drawing (Dimensions are in mm)

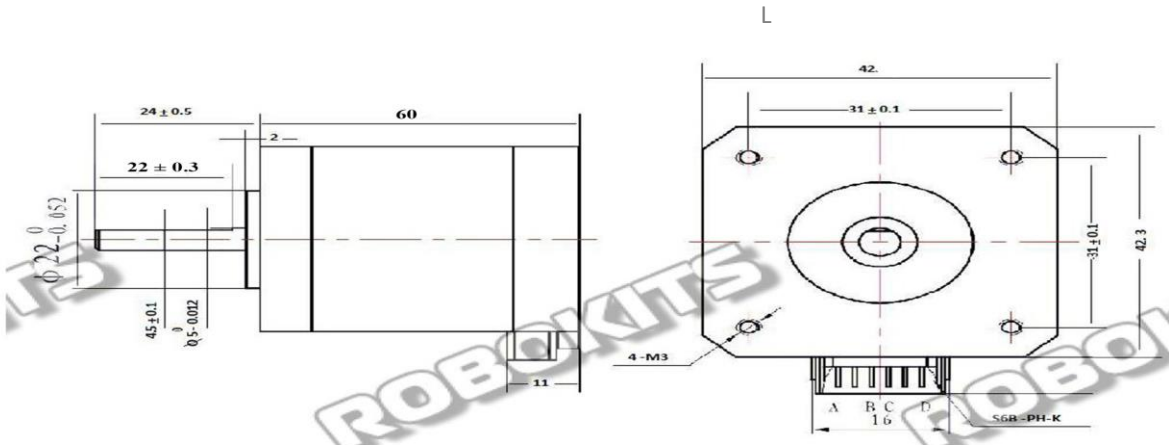

Technical specifications of Motor

Motor Type	Stepper Motor
Step Angle	1.8°
Rated voltage	5.1 VDC
Holding Torque(Kgcm)	7 Kgcm
Configuration	4 wire Bipolar
Rated Current (A)	1.7
Resistance Per Phase (10%E)	1.5
Inductance Per Phase (20%mH)	2.8
Insulation Class	Class B
Number of Phase	2
Shaft type	D- Shaft
Shaft Length	24mm
Motor Length without shaft	60 mm
Weight	450 grams



RHINO

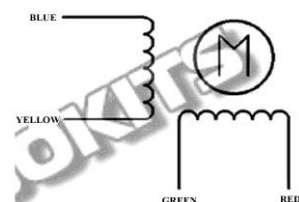

Wiring Diagram