

Model Number
RMCS-5031

Rhino Planetary Geared Quad Encoder 100RPM 25Kgcm DC Servo Motor

Mechanical Drawing (Dimensions are in mm)

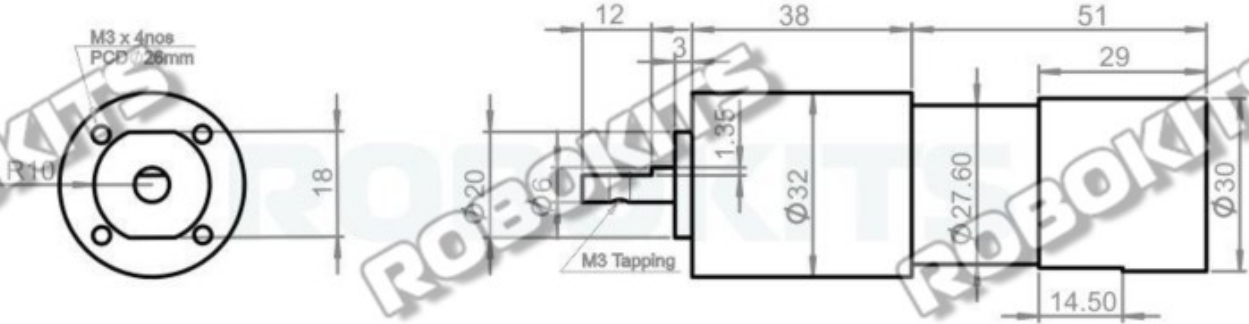

Technical specifications of Motor

Motor Type	Planetary Geared Motor
Operating voltage	12V DC
Motor Speed at Output Shaft (RPM)	103RPM
Stall Torque(Kgcm)	100Kgcm but not exceed more than 75Kgcm
Rated Torque(Kgcm)	25Kgcm
Gear Ratio	1 : 174
CPR at Output Shaft of Motor	9048
Weight	300gm

Encoder Pinouts

Encoder Type	Quad Encoder
Quad Encoder	13 Hall Sensor
Base Motor CPR	13*4=52
Red	EncA
Orange	EncB
Yellow	Motor-
Green	Motor+
Brown	+5V DC
Black	Gnd

Base Motor Specifications

Nominal voltage(V)	12V
No-Load Speed (RPM)	18000
Rated Torque (gcm)	151
No-load current (A)	0.8A
Load current(A)	up to 7.5 A(Max)

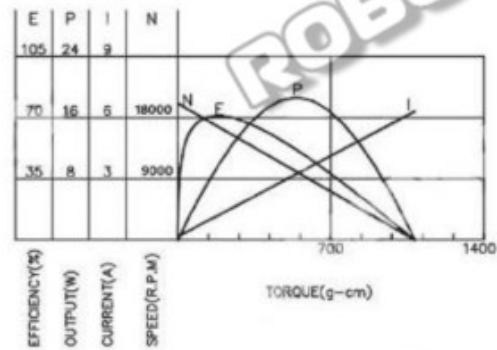

Base Motor Characteristic Graph

